

Effect of surfactant polyoxyethylene glycol (C₁₂E₈) on electroporation of cell line DC3F

Maša Kandušer^a, Miha Fošnarič^a, Marjeta Šentjurs^b, Veronika Kralj-Iglič^c, Henry Hägerstrand^d, Aleš Iglič^a, Damijan Miklavčič^{a,*}

^a Faculty of Electrical Engineering, University of Ljubljana, SI-1000, Ljubljana, Tržaška 25, SI-1000 Ljubljana, Slovenia

^b J. Stefan Institute, SI-1000, Ljubljana, Slovenia

^c Faculty of Medicine, University of Ljubljana, SI-1000, Ljubljana, Slovenia

^d Department of Biology, Åbo Akademi University, FIN-20520, Åbo/Turku, Finland

Received 28 October 2001; accepted 20 August 2002

Abstract

Surfactant polyoxyethylene glycol (C₁₂E₈) decreases the voltage required for irreversible electroporation in planar lipid bilayers. In our study the effect of non-cytotoxic concentration of C₁₂E₈ on cell membrane reversible and irreversible electroporation voltage was investigated in DC3F cell line. Cell suspension was exposed to a train of 8 electric pulses of 100 μs duration, repetition frequency 1 Hz and amplitudes from 0 to 400 V at electrode distance 2 mm. The effect of C₁₂E₈ on the reversible and irreversible electroporation was investigated. We found that C₁₂E₈ decreases the voltage necessary for irreversible electroporation but has no effect on reversible electropermeabilization. Cell membrane fluidity measured by electron paramagnetic resonance spectrometry, using the spin probe methylester of 5-doxyl palmitate was not significantly changed due to the addition of C₁₂E₈. Based on this we conclude that the main reason for the observed effect were not the changes in the membrane fluidity. As an alternative explanation we suggest that C₁₂E₈ induced anisotropic membrane inclusions may stabilize the hydrophilic pore, by accumulating on a toroidally shaped edge of the pore and attaining favorable orientation.

© 2002 Elsevier Science B.V. All rights reserved.

Keywords: Polyoxyethylene glycol; C₁₂E₈; Electroporation; Membrane fluidity; DC3F; Anisotropic membrane inclusions

1. Introduction

The cell membrane represents a semi-permeable barrier between the cell interior and its surround-

ings. The application of high intensity electric pulses of short duration causes permeabilization of cell membrane termed electropermeabilization or electroporation [1,2]. Electroporation is widely used in biotechnology for gene transfer and has a good prospect to be used in gene therapy [3]. In clinical oncology electroporation is already used in combination with chemotherapy as a method termed electrochemotherapy [4–6].

* Corresponding author. Tel.: +386-1-4768456; fax: +386-1-4264658

E-mail address: damijan@svarun.fe.uni-lj.si (D. Miklavčič).

There are different theoretical models that describe mechanisms of electroporation of cell membrane. Among them the electroporation model is the most widely accepted and accounts for the key electroporation phenomena [7]. According to this model in the presence of an external electric field, hydrophilic pores are formed in the cell membrane [7,8]. The number of hydrophilic pores formed due to exposure to electric pulses is depending on the voltage applied, and is thus a continuous process. Increased membrane permeability however is a threshold phenomenon since the increased flow is observed once the number of hydrophilic pores per membrane area is sufficiently high [9]. Namely, the external electric field must reach a critical value to induce a threshold transmembrane potential that leads to increased membrane permeability [2]. We use the term ‘reversible electroporation’ in those cases in our study when we observe membrane permeabilization and the term ‘irreversible electroporation’ when we observe cell death due to membrane rupture. Both phenomena are described in the existing literature on electroporation; reversible (when cell membrane reseals and cell survives) or irreversible (when cell membrane cannot reseal and cell dies) [10–15]. The electroporation depends on different parameters among which the parameters of external electric field (electric field strength, duration and number of pulses) have been studied extensively [14,16–24]. The choice of these parameters determines whether the electroporation is reversible or irreversible in nature. Besides parameters of electric field, other parameters have been shown to affect electroporation; among those, the physical properties of the cell membrane, such as membrane fluidity. The study of the cell culture of Chinese hamster ovary cells treated with ethanol and lysolecithin, which incorporate into the cell membrane and change the membrane fluidity, shows that electroporation behavior of treated cells is affected [13].

Nevertheless, little is known about the effect of surfactants on cell membrane electroporation. Surfactants are a group of amphiphilic substances that incorporate in the cell membrane and change its properties [25,26]. The polyoxyethylene glycol surfactant $C_{12}E_8$ is widely used as a solubilizer of

membrane proteins. Its critical micellar concentration is 0.09 mM [27]. The results of previous studies indicate a rapid flip–flop of $C_{12}E_8$ across the lipid and cell membranes [28–30]. Effects of $C_{12}E_8$ on the cell membrane depend on its concentration. At sub-solubilizing concentration, $C_{12}E_8$ perturbs membrane structure and function and changes its physical properties [27,31,32]. The $C_{12}E_8$ molecules, while bound in the membrane bilayer, may form $C_{12}E_8$ –phospholipid [32,33] and $C_{12}E_8$ –protein [34] complexes that we call inclusions [33,35,36]. It was shown that in POPC planar lipid bilayers $C_{12}E_8$ significantly lowers the voltage required for irreversible electroporation [37].

The aim of the present study was to test the effect of a non-cytotoxic concentration of $C_{12}E_8$ on reversible and irreversible electroporation of cells in vitro and to investigate the possible mechanisms responsible for these phenomena. Therefore, a non-cytotoxic concentration of $C_{12}E_8$ was chosen which did not change the membrane fluidity. The possible mechanism of stabilization of the hydrophilic pores by $C_{12}E_8$ molecules was studied theoretically.

2. Experiments

2.1. Materials and methods

2.1.1. Cells

Transformed Chinese hamster lung fibroblast cells, DC3F, were used. Cells were grown in Eagle’s minimum essential medium with Earle’s salts, 2 mM L-glutamine (Sigma-Aldrich Chemie GmbH, Deisenhofen, Germany), sodium bicarbonate (Braun, Melsungen, Germany), benzyl penicillin (Crystacillin, Pliva d.d., Zagreb, Croatia) and gentamicin sulphate (Lek d.d., Ljubljana, Slovenia), supplemented with 10% fetal bovine serum (Sigma-Aldrich Chemie GmbH). The cells were maintained at 37 °C in a humidified atmosphere that contained 5% CO₂ for 3–4 days to obtain confluent culture from which the cell suspension was prepared with 0.05% trypsin solution containing 0.02% EDTA (Sigma-Aldrich Chemie GmbH).

2.1.2. Cytotoxicity of $C_{12}E_8$ on cell culture

To determine cytotoxicity of $C_{12}E_8$ (Fluka, Sigma-Aldrich Chemie GmbH) the cell suspension was incubated with a sub-solubilization concentration (0.5, 5 and $13 \mu\text{g ml}^{-1}$) of $C_{12}E_8$ in Spinner modification of Eagle's minimum essential medium (Life Technologies Ltd, Paisley, UK) for 1 h at 37° (treated cells) while untreated cells were incubated with Spinner modification of Eagle's minimum essential medium for the same time at the same temperature. After incubation the cells were diluted in Eagle's minimum essential medium and plated in the same medium supplemented with 10% fetal bovine serum in concentration 200 cells per Petri dish for clonogenic test. Colonies grown for 5 days were fixed with methanol (Merck KGaA, Darmstadt, Germany) and stained with crystal violet (Sigma-Aldrich Chemie GmbH). Colonies were counted and results normalized to untreated cells and expressed as a percentage of survival. Results of four independent experiments were pooled and presented as mean \pm S.E. Differences between untreated and $C_{12}E_8$ treated cells were tested by Student *t*-test. For further experiments, a ten times lower concentration than the one that was determined as non-cytotoxic was used (i.e. $0.05 \mu\text{g ml}^{-1}$ $C_{12}E_8$).

2.1.3. Cell membrane fluidity measurements

The cells in suspension were incubated for 45 min at 37°C ; $0.05 \mu\text{g ml}^{-1}$ $C_{12}E_8$ was added to treated cells, while the medium in which $C_{12}E_8$ was dissolved was added to untreated cells. The membrane fluidity was measured by electron paramagnetic resonance method (EPR), using the spin probe methylester of 5-doxyl palmitate (MeFASL (10,3)), which is lipophilic and therefore incorporates primarily into the membrane lipid bilayer [38]. Sixty milliliters of 0.1 mM MeFASL (10,3) in ethanol solution was placed into the glass tube, then ethanol was evaporated by rotavapor. 1 ml of cell suspension that contained 20×10^6 cells was added to the MeFASL film formed on the wall of the glass tube, and incubated for 15 min while shaking. After that, the cell suspension was centrifuged and the pellet was placed in glass capillary for EPR measurements. From the EPR spectra at 4°C , the maximal hyperfine splitting

constant $2A_{\text{II}}$ that reflects the order parameter was measured. At 37°C , the empirical rotational correlation time (τ_c) that reflects rotation of the low and middle field amplitudes, was calculated using the following equation: $\tau_c = K\Delta H_0\sqrt{h_{-1}/h_0}$ (Fig. 1). Both parameters reflect ordering and dynamics of phospholipids in the membrane bilayer and are the measure of membrane fluidity [39]. Each measurement was repeated three times in three independent experiments. Differences between untreated and $C_{12}E_8$ treated cells were tested by the Student *t*-test.

2.1.4. Electroporation

To determine the effect of non-cytotoxic concentration of $C_{12}E_8$ (that does not affect membrane fluidity) on reversible electroporation, the cell suspension was prepared in Spinner modification of Eagle's mini-

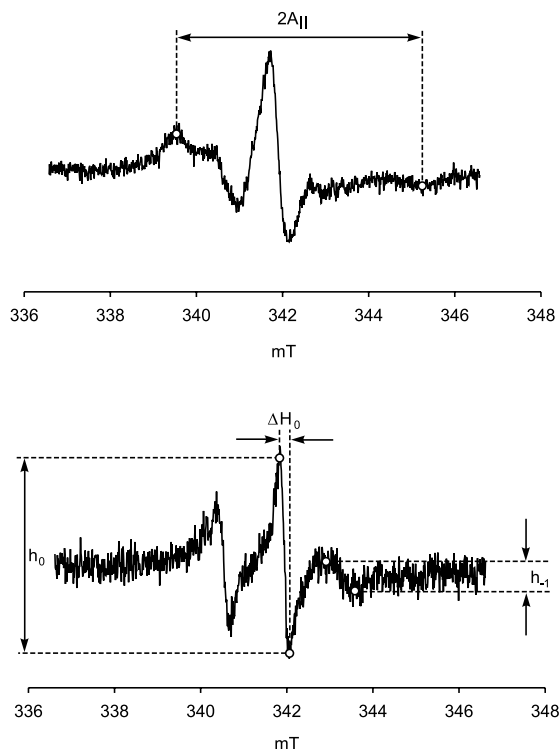

Fig. 1. Typical EPR spectra of DC3F cells at 4°C (A) and at 37°C (B). At 4°C the maximal hyperfine splitting constant $2A_{\text{II}}$ was measured, and at 37°C the empirical rotational correlation time (τ_c) was calculated from h_0 , ΔH_0 and h_{-1} .

medium essential medium. Before electroporation was performed, bleomycin was added to the cell suspension in final concentration of 5 nM. At this concentration, bleomycin is non-cytotoxic as the cell membrane is impermeant for this substance [40]. When the electroporation takes place bleomycin gains access to the cell interior and provokes cell death [40]. In this way reversible electroporation is detected. In all experiments, cell suspension was incubated with $C_{12}E_8$ as described above for the cell membrane fluidity measurements. A 50 μl droplet of cell suspension that contained 10^6 cells was placed between stainless steel electrodes, which were 2 mm apart. The train of 8 square pulses, 100 μs of duration and of the repetition frequency 1 Hz was generated (we used a prototype electroporator developed in our laboratory at the University of Ljubljana, Faculty of Electrical Engineering, Slovenia [41]). The voltage from 0 (control) to 400 V in 40 V steps was applied. Cells were then incubated at room temperature for 30 min to allow cell membrane resealing. After that the uptake of bleomycin was determined by clonogenic test as already described above for cytotoxicity experiments. Cell colonies were counted for untreated and $C_{12}E_8$ treated cells and results were normalized to the corresponding results of the control, i.e. cells that were not exposed to electric pulses. The percentage of colonies was subtracted from 100 percent to obtain the percentage of permeabilized cells. Results of five independent experiments were pooled and presented as a mean value \pm S.E. Differences between the untreated and the $C_{12}E_8$ treated cells were tested by the Student *t*-test.

To determine the effect of the non-cytotoxic concentration of $C_{12}E_8$ on irreversible electroporation, the protocol that is described above was used without the addition of bleomycin.

To gain more information about the effect of $C_{12}E_8$ on irreversible electroporation, additional experiments were performed. The cell suspension was electroporated using the same protocol as described above while $C_{12}E_8$ was added immediately after the application of the train of 8 pulses when the cell membrane is still permeable for small molecules like $C_{12}E_8$. Cell survival was determined by the clonogenic test as described above. The

results of three independent experiments were pooled and presented as a mean value \pm S.E. Differences between the untreated and the $C_{12}E_8$ treated cells were tested by Student *t*-test.

The results of the permeabilization and the cell survival with respect to the applied electric field (i.e. voltage applied on the electrodes) are reported. The nominal electric field for the geometry and dimensions of the electrodes used in our experiments can be estimated as the voltage applied to the electrodes divided by the distance between the electrodes.

2.2. Experimental results

2.2.1. The cytotoxic effect of $C_{12}E_8$ on the cell culture and cell membrane fluidity

The cytotoxic effect of different concentrations of $C_{12}E_8$ was tested to establish the non-cytotoxic concentration. The results show that sub-solubilizing concentrations of $C_{12}E_8$ (lower than 0.5 $\mu\text{g ml}^{-1}$), 60 min incubation at 37 °C are non-cytotoxic for the DC3F cell line (Table 1).

The maximal hyperfine splitting $2A_{\text{II}}$ of the EPR spectra, which reflects the order parameter of the membrane lipids and the empirical rotational correlation time τ_c were measured (Fig. 1). No differences were found by Student *t*-test between the $C_{12}E_8$ treated and the untreated cells (Table 2). From these results, we conclude that $C_{12}E_8$ at non-cytotoxic concentration of 0.05 $\mu\text{g ml}^{-1}$ affects neither the order parameter (packing of phospholipids) nor the dynamics of the motion of lipids in the bilayer of the DC3F cell line due to the low molar ratio of $C_{12}E_8$ to membrane phospholipids.

Table 1
Cytotoxic effect of different concentrations of $C_{12}E_8$ $\mu\text{g ml}^{-1}$ on cell line DC3F

$C_{12}E_8$ $\mu\text{g ml}^{-1}$	Survival (% of control)	<i>t</i> -test
0	100 \pm 0	
0.5	92 \pm 3	<i>P</i> = 0.06
5	49 \pm 9	<i>P</i> = 0.03
13	20 \pm 8	<i>P</i> = < 0.001

Cell suspension was incubated for 60 min at 37 °C. Values are means of 4 experiments \pm S.E.

Table 2

Order parameter and rotational correlation time in DC3F cell line after 45 min incubation with SMEM control and with $C_{12}E_8$ at concentration $0.05 \mu\text{g ml}^{-1}$ treated cells

	Control	$C_{12}E_8$	<i>t</i> -test
Order parameter $2A_{II}$ (mT)	5.81 ± 0.4	5.71 ± 1.4	NS
Rotational correlation time τ_c (ns)	2.07 ± 0.02	2.21 ± 0.14	NS

Values are means of 3 experiments \pm STD.

2.2.2. Electroporation

The electroporation experiments revealed that $C_{12}E_8$ does not affect the reversible electroporation, however, it significantly increases the irreversible electroporation i.e. the irreversible electroporation occurs at lower applied voltages. The differences between the $C_{12}E_8$ treated cells and the control was most pronounced when the cell suspension was exposed to the train of 8 pulses and voltages 160V ($P=0.037$) and 200V ($P=0.022$), as shown by Student *t*-test (Fig. 2). The addition of $C_{12}E_8$ caused the cell death at the same voltage at which the reversible electroporation takes place. This can be explained by a pore

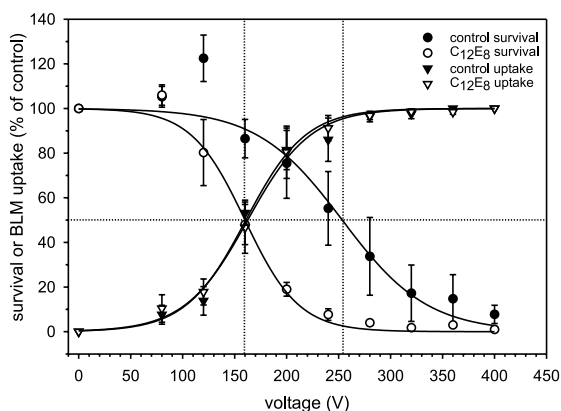

Fig. 2. The effect of $C_{12}E_8$ on reversible and irreversible electroporation measured by bleomycin uptake and cell survival, respectively on cell line DC3F. The train of 8 pulses, 100 μs , and repetition frequency 1 Hz was applied. The voltage of each train of pulses applied to 2 mm stainless steel electrodes was 0, 80, 120, 160, 200, 240, 280, 320, 360 and 400 V. Cell suspension was incubated with $0.05 \mu\text{g ml}^{-1}$ $C_{12}E_8$ for 45 min ($C_{12}E_8$) or with electroporation medium (control). Values are means of 5 experiments \pm S.E.

stabilization effect of $C_{12}E_8$ as explained in detail in our theoretical considerations. We presume that hydrophilic pores are formed at the voltage at which reversible electroporation takes place and that these pores are prerequisite for the bleomycin access to the cell interior that causes cell death. On the other hand cell death that is a consequence of irreversible electroporation is caused by electric field itself that provokes irreversible changes in the cell membrane. In control cells, which were not treated with $C_{12}E_8$ so that the pore stabilization did not occur, 50% of the cells survived the application of pulses of the amplitude of 250 V. In these cells, a resealing of the cell membrane took place while in the $C_{12}E_8$ treated cells no cell survived the application of pulses of the amplitude of 250 V, as the resealing was prevented by $C_{12}E_8$ (Fig. 2). In control cells, we observe 50% of the permeabilization as determined by bleomycin uptake at 160 V. At the same voltage, in the $C_{12}E_8$ treated cells, we observe 50% of the permeabilization and also only 50% of cell survival after treatment with electric field (Fig. 2). This shows that the irreversible electroporation of the $C_{12}E_8$ treated cells is shifted to the same voltage at which reversible electroporation occurs. In other words, electropermeabilization in the presence of $C_{12}E_8$ becomes irreversible as soon as it occurs. These results lead us to the conclusion that stabilization of the hydrophilic pores is responsible for the observed behavior as described latter in the theoretical part of this work.

To confirm our conclusion we performed additional experiments. From the described experiments we could not distinguish between the pore stabilization effect of $C_{12}E_8$ and the possibility that $C_{12}E_8$ could be toxic when it has access to cell interior. Therefore, in these additional experiments the $C_{12}E_8$ was added immediately after the application of the train of 8 pulses. We showed that $C_{12}E_8$ was not cytotoxic when it gained access to the cell interior (Fig. 3), as after electroporation the cell membrane remains permeable for small molecules such as $C_{12}E_8$. From these results we concluded that the cell death observed in the previous experiment (Fig. 2) had to be caused by the effect of $C_{12}E_8$ on the pore stabilization and

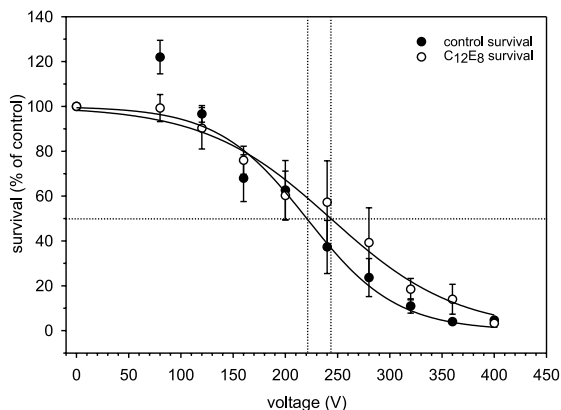

Fig. 3. The effect of C₁₂E₈ added immediately after application of electric pulses on irreversible electroporation measured by cell survival on cell line DC3F. The train of 8 pulses, 100 μ s, and repetition frequency 1 Hz was applied. The voltage of each train of pulses applied to 2 mm stainless steel electrodes was 0, 80, 120, 160, 200, 240, 280, 320, 360 and 400 V. 0.05 μ g ml⁻¹ C₁₂E₈ (C₁₂E₈) or electroporation medium (control) was added to electroporated cells. Values are means of 3 experiments \pm S.E.

that C₁₂E₈ has to be incorporated in the cell membrane at pulse application.

3. Theoretical considerations

In this section, we present the theory that describes the formation of hydrophilic pores, which are responsible for increased membrane permeability [7]. Within this theory, a possible role of C₁₂E₈ membrane inclusions in the increased stability of hydrophilic pores [9,42] is described. A circular segment of a planar lipid bilayer with a hydrophilic circular pore in the center is studied. The formation of the hydrophilic pore in a lipid bilayer implies the existence of a bilayer edge [28,43]. In the process of pore formation the membrane constituents attain a configuration where the polar parts are used to shield the hydrophobic parts from the water (Fig. 4).

For the sake of simplicity we assume a molecular arrangement, where both membrane layers at the edge of the pore bend towards each other [28,9], forming an inner half of the torus (Fig. 4). We consider a flat circular bilayer membrane segment of a radius l and of a thickness $2r$, having

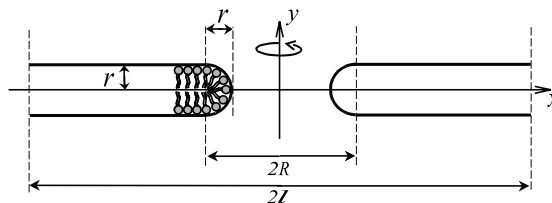

Fig. 4. Cross section of the geometrical model of the circular membrane bilayer segment with a toroidal pore in the center. The whole segment and the pore are assumed to have rotational symmetry around the y -axis. R is the radius of the pore and $2r$ is the distance between the surfaces of both layers at the flat part of the segment. Principal membrane curvatures C_1 and C_2 are zero in the region $R < x < l$, where the membrane is flat. In the region $R-r < x < R$ one of the principal curvatures is $C_1 = 1/r$, and the other is $C_2 = (x-R)/rx$.

a toroidal pore of a radius R at its center. Due to the rotational symmetry of the segment around the y -axis, the orientation of the x -axis in the $y=0$ plane is arbitrary. Outside the outer border of the circular bilayer segment (i.e. for $x > l$) the membrane bilayer remains flat, however these parts are not considered in our calculations (periodical boundary conditions are imposed at $x=l$). We describe the shape of the membrane with two principal curvatures, C_1 and C_2 , given at each point on the membrane. Both principal membrane curvatures are zero in the region $R < x < l$, where the membrane is flat. In the region of the inner half of the torus ($R-r < x < R$) one of the principal membrane curvatures is constant, $C_1 = 1/r$, while the other is $C_2 = (x-R)/rx$ (Appendix A).

It was recently suggested [37] that C₁₂E₈ lowers the voltage required for irreversible electroporation of planar lipid bilayers. This increased susceptibility of lipid bilayers to electroporation could be related to the specific effect of the C₁₂E₈ molecules that changes the macroscopic physical properties of the membrane in a way that the formation of the pores becomes energetically more favorable. It was also proposed that C₁₂E₈ could be cooperatively bound in the region of the pore edge, which may stabilize the pore shape [30]. This scheme assumes an increased local area density of C₁₂E₈ in the region of the pore edge and rapid transport of C₁₂E₈ across the membrane [30]. The last assumption is in accordance with some recent

experimental results of the same authors [29] and also with the results [28,29].

It is known that $C_{12}E_8$ molecules may interact with membrane proteins and form $C_{12}E_8$ –protein complexes (inclusions) [34]. Therefore $C_{12}E_8$ may solubilize membrane proteins and change the membrane protein activity [34]. It has also been shown recently that the cooperative interaction of $C_{12}E_8$ with larger number of neighboring lipid molecules [32] may lead to the formation of the $C_{12}E_8$ –lipid membrane inclusions (clusters/rafts) [33,36]. Recent experimental results show that the effective shape of the lipid molecules interacting with the $C_{12}E_8$ molecule is changed because the acyl chains of the lipid molecules are moved apart sideways [31,32]. Therefore, the effective intrinsic shape of the $C_{12}E_8$ –lipid inclusion may be in general anisotropic [33,36] (see also Fig. 5). Also, the effective intrinsic shape of the detergent/protein membrane inclusion may be in general

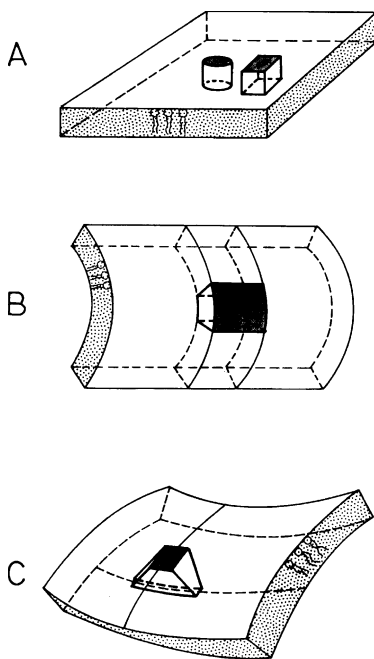

Fig. 5. Schematic figure illustrating different intrinsic shapes of the membrane inclusions characterized by the two principal curvatures C_{1m} and C_{2m} . Shading marks the hydrophilic surface of the inclusion. The characteristic intrinsic shapes of inclusions are shown in the figure: $C_{1m} = C_{2m} = 0$ (A), $C_{1m} > 0$, $C_{2m} = 0$ (B) and $C_{1m} > 0$, $C_{2m} < 0$ (C). The corresponding most favorable membrane surfaces are also shown.

anisotropic [35,50,51,44,45]. In the present work the possible role of the effective intrinsic shape of the complexes formed by $C_{12}E_8$ molecules and the neighboring membrane constituents in the stability of the membrane hydrophilic pore is studied theoretically.

In order to obtain the equilibrium shape of the hydrophilic pore in the planar membrane bilayer segment we are looking for the minimum of the membrane free energy (F) as the sum of the pore edge energy (W_b) and the contribution of the $C_{12}E_8$ membrane inclusions (F_i),

$$F = W_b + F_i. \quad (1)$$

The edge energy (line tension) of the pore [9,46] is approximated by the (monolayer) bending energy [47,48] of the pore (W_b):

$$W_b = \frac{1}{2}k_c \int_A 4\bar{C}^2 dA + \frac{1}{2}k_G \int_A C_1 C_2 dA, \quad (2)$$

where k_c is the local bending modulus, k_G is the Gaussian bending modulus, $\bar{C} = (C_1 + C_2)/2$, A is the area of the membrane segment and dA is the infinitesimal membrane area element. For the Gaussian bending modulus it is taken that $k_G = -2k_c$ [49,52]. For the sake of simplicity, the spontaneous curvature was not included in Eq. (2).

The $C_{12}E_8$ membrane inclusions may be $C_{12}E_8$ /lipid complexes and/or $C_{12}E_8$ –protein complexes. However, in this work, all the inclusions are for the sake of simplicity considered as equal. In general, the effective intrinsic shape of the inclusions is considered as anisotropic. The contribution of the $C_{12}E_8$ induced membrane inclusions to the membrane energy can be written in the form [51,36,44]:

$$F_i = -NkT \ln \left[\frac{1}{A} \int q I_0 \left(\frac{\xi + \xi^*}{2kT} \hat{C} \hat{C}_m \right) dA \right], \quad (3)$$

where q is defined as

$$q = \exp \left[-\frac{\xi}{2kT} (\bar{C} - \bar{C}_m)^2 - \frac{\xi + \xi^*}{4kT} \times (\hat{C}^2 + \hat{C}_m^2) \right], \quad (4)$$

ξ and ξ^* are the constants representing the

strength of the interaction between the inclusion and the membrane continuum, $\hat{C} = (C_1 - C_2)/2$, $\bar{C}_m = (C_{1m} + C_{2m})/2$, $\hat{C}_m = (C_{1m} - C_{2m})/2$, where C_{1m} and C_{2m} are the principal curvatures of the intrinsic shape (Fig. 5) of the inclusion, N is the total number of the inclusions in the membrane bilayer segment, I_0 is the modified Bessel function of the first kind, k is the Boltzmann constant and T is the temperature. It is taken for simplicity that $\zeta = \zeta^*$ [51]. Due to the rapid $C_{12}E_8$ transport across the membrane [28–30] we assumed that $C_{12}E_8$ inclusions are equally distributed between both membrane layers in the membrane region around the pore (the trans-bilayer transport of $C_{12}E_8$ molecules can be partially carried out also due to lateral flow of $C_{12}E_8$ through the membrane pores).

For fixed values of parameters r , ε , κ and for fixed C_{1m} and C_{2m} , the membrane free energy is a function only of the radius of the pore R , i.e. $F(R) = W_b(R) + F_i(R)$, and we can search for the value ($R = R_{\min}$), which gives the minimal possible relative membrane free energy: $F_{\min} = F(R_{\min})$. The area A of the membrane segment must remain constant throughout the minimization, so when the size of the hydrophilic pore is changed, the radius of the segment (l) must change accordingly.

The pore edge (bending) energy W_b is a monotonically increasing function of the radius of the pore R (Appendix A). Therefore $W_b(R)$ does not have a minimum for R larger than r , which is the smallest possible radius of the pore in the described model. The membrane bending energy is minimal when the membrane surface is completely flat and without pores. Any anomaly in the flatness of the membrane surface increases its bending energy.

The relative free energy of the membrane inclusions $F_i/8\pi\kappa_c$ and the relative total membrane free energy $F_i/8\pi\kappa_c = (W_b + F_i)/8\pi\kappa_c$ as functions of the radius of the pore R are shown in Fig. 6 for three different intrinsic shapes of inclusions. Fig. 6(A) shows the case of a conical isotropic intrinsic shape of the inclusions ($C_{1m} = C_{2m}$). It can be seen, that for isotropic inclusions the energy F_i decreases monotonically with increasing R . Summation of W_b and F_i gives us the total membrane free energy F , which can have a minimum for a particular

radius of the pore $R = R_{\min}$. The number of inclusions N enters the expression (3) as the multiplication factor. Since $F_i(R)$ is a monotonically decreasing function for isotropic inclusions and $W_b(R)$ is monotonically increasing, we can always find such N , that the sum $F = W_b + F_i$ will have a minimum. However, the position and the existence of such minimum depend very strongly on the value of N . Also, such pores with isotropic inclusions are unrealistically large (≈ 100 nm). A much stronger argument for the stability of the pore would be a minimum in the function $F_i(R)$ itself. This would also indicate that inclusions favor a particular size of the pore. The local minimum actually appears in the function $F_i(R)$ if the shape of the inclusions is sufficiently anisotropic, with $C_{1m} < 0$ and $C_{2m} > 0$. For illustration, Fig. 7 shows the calculated radius of the stable pore (R_{\min}) as the function of C_{1m} . With the constant value $C_{2m} = 1/r$, we have isotropic inclusions at $C_{1m} = 1/r$ (indicated as point A in Fig. 7). With decreasing value of C_{1m} , the shape of the inclusions becomes more and more anisotropic. When the intrinsic shape of the inclusions becomes anisotropic enough, i.e. when $|\hat{C}_m|$ is large enough, inclusions start to favor the toroidal shape of the edge of the pore and the local minimum appears in the function $F_i(R)$. Fig. 6(B) corresponds to the point B in Fig. 7, where the local minimum just begins to appear. In Fig. 6(C) it can be seen, that inclusions with $C_{1m} = -0.5/r$ and $C_{2m} = 1/r$ strongly stabilize the pore of a radius $R_{\min} = 2.9r$.

Based on the presented results it can be concluded that anisotropic inclusions can significantly contribute to stabilization of hydrophilic pores in bilayer membranes. The radii of such pores are of the order of the membrane thickness. On the other hand, the pores with isotropic inclusions are very weakly stabilized and are unrealistically large.

4. Discussion

The question addressed by the present study was how non-cytotoxic concentrations of surfactant $C_{12}E_8$ affect the electroporation behavior of the cell line DC3F. The main finding is that incubation of cell suspension with $C_{12}E_8$ at non-cytotoxic

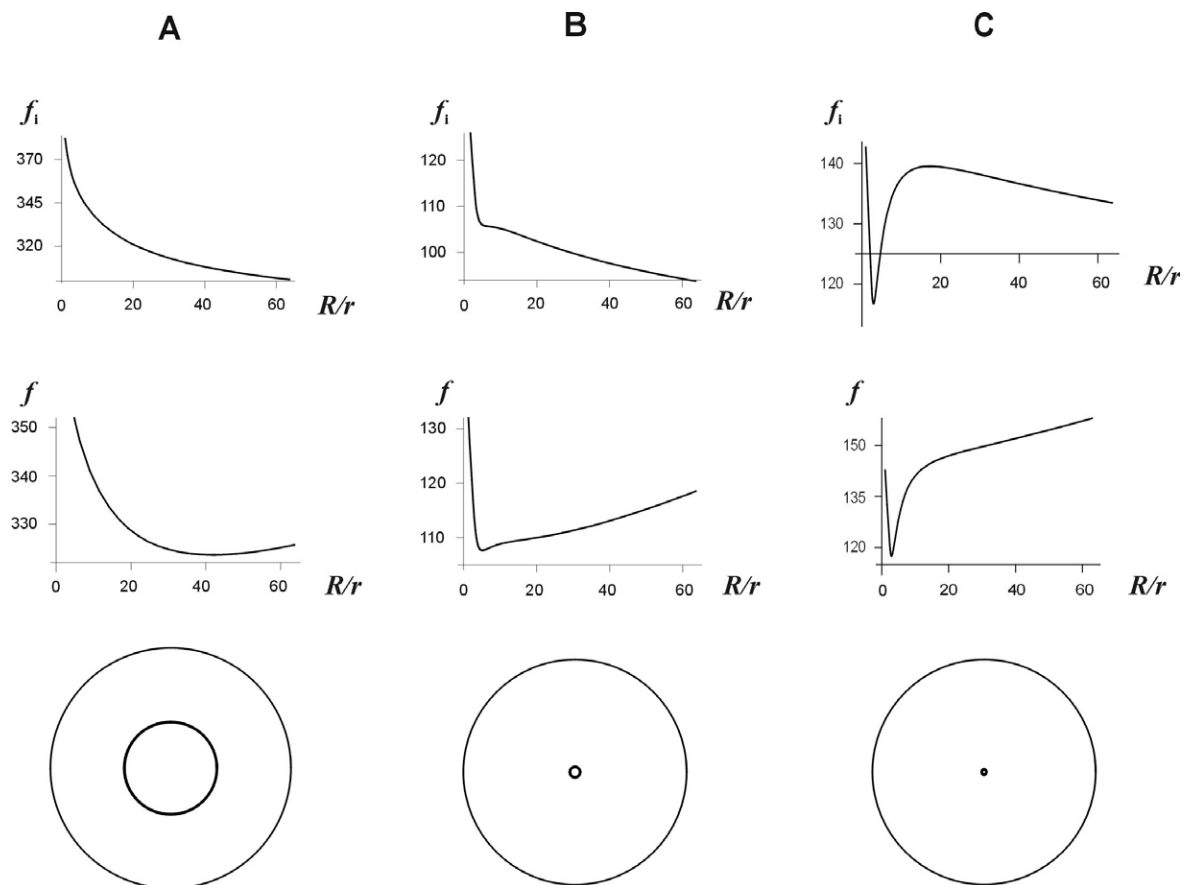

Fig. 6. The relative free energy of the inclusions ($f_i = F_i/8\pi\kappa_c$) and the relative membrane total free energy ($f = F/8\pi\kappa_c$) as functions of the relative radius of the pore (R/r) calculated for conical isotropic intrinsic shape of inclusions with $C_{1m} = C_{2m} = 1/r$ (A) and for two different anisotropic intrinsic shape of the inclusions: $C_{1m} = -0.3/r$, $C_{2m} = 1/r$ (B) and $C_{1m} = -0.5/r$, $C_{2m} = 1/r$ (C). The membrane segment free energy reaches minimum at: (A) $R_{\min} = 42r$, (B) $R_{\min} = 5.2r$ and (C) $R_{\min} = 2.9r$. The corresponding membrane segments with a pore with radius R_{\min} are also shown in the bottom. The outer circles represent the outer borders of the membrane segments and the inner circles represent the edges of the pores in the center. The values of parameters are: $\varepsilon = 10$, $\kappa = 100$, $A/4\pi r^2 = 10^4$ (the values are within the previously estimated range [51]).

concentration of $0.05 \mu\text{g ml}^{-1}$ (which does not affect membrane fluidity) significantly decreases voltage for irreversible electroporation when the train of 8 pulses at frequency 1 Hz is applied. We propose that pore stabilization due to the incorporation of $C_{12}E_8$ into the cell membrane is the physical mechanism that may explain these experimental observations.

Incubation of cell suspension with non-cytotoxic concentration of $0.05 \mu\text{g ml}^{-1}$ (i.e. $0.09 \mu\text{M}$) $C_{12}E_8$ for 45 min does not affect cell membrane fluidity (Table 1) however, it reduces irreversible electroporation for 63% compared with untreated cells

(Fig. 2). These results are in agreement with previous results obtained on planar lipid bilayers [37]. On planar lipid bilayers, the electroporation with $100 \mu\text{s}$ pulses and simultaneous addition of $1 \mu\text{M}$ $C_{12}E_8$ reduced irreversible electroporation (measured as a voltage at which the membrane rupture takes place) for 69% with respect to untreated POPC membranes. Our results indicate that the reason for this effect could not be the changes in the membrane fluidity caused by incorporation of $C_{12}E_8$ into the cell membrane since $C_{12}E_8$ in concentration of $0.09 \mu\text{M}$ does not cause significant changes in membrane fluidity

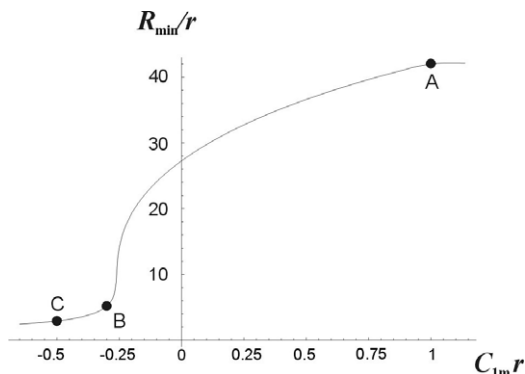

Fig. 7. The relative equilibrium radius of the pore R_{\min} as the function of C_{1m} , for $C_{2m} = 1/r$. The points A, B and C denote the values of R_{\min} for the corresponding Fig. 6(A–C). The values of parameters ε , κ and A are the same as given in Fig. 6.

(Table 2). Although $C_{12}E_8$ increase membrane fluidity in POPC membranes [31,32], the molar ratio of phospholipids to $C_{12}E_8$ in our study was one order of magnitude lower than in published studies that report this effect of $C_{12}E_8$. The possibility that the effect of $C_{12}E_8$ on irreversible electroporation was the consequence of cytotoxic effect $C_{12}E_8$ when it has access to cell interior was disproved in the experiment when $C_{12}E_8$ was added immediately after pulse application (Fig. 3). In accordance, we proposed a mechanism that may explain our experimental results. Our explanation is based on the findings obtained in planar lipid bilayers where it was hypothesized that in voltage induced metastable conductive pores hypothetical contaminants gradually replace the background lipids at the pore edge to lower its energy [53]. The effect of $C_{12}E_8$ on irreversible electroporation can be explained similarly. As shown by our theoretical study, $C_{12}E_8$ may stabilize pores by incorporation into the hydrophilic pores thereby preventing resealing of the cell membrane after electroporation and consequently causing cell death. This agrees with our experimental results (Fig. 2). In our theoretical model, a hydrophilic pore was considered as a toroidal pore in a center of a circular flat membrane segment. For a lipid bilayer with thickness $2r \cong 5$ nm, the radius of the pore for isotropic inclusions is in the range of 100 nm (Fig. 6(A)). Although the minimum in the total membrane free energy was found

for isotropic inclusions, the corresponding pores are unrealistically large. On the other hand, if the inclusions have an anisotropic intrinsic shape, the energy contribution of $C_{12}E_8$ inclusions itself can have a minimum for the specific size of the pore. For anisotropic inclusions, the radius of the pore is in the range of the thickness of the bilayer (Fig. 6(C)).

It must be emphasized that the proposed expression for the continuum bending energy that was used for the pore edge energy (Eq. (2)) was originally derived for small principal curvatures [48]. In our case, at least one principal curvature is very large. Therefore the correct expression for the pore bending energy should in general include also higher terms than quadratic. However, in our theoretical model the major effect that stabilizes the pore originates from the energy of the membrane inclusions ($F_i(R)$), so the inaccuracy of the expression (2) for the edge energy of the pore does not have a great significance for the interpretation of our main theoretical predictions.

In the described theoretical approach the area density of the membrane inclusion is in general non-homogeneous. Namely, the local area density of membrane inclusions in the region of the pore edge could be very high although the area density of inclusions far from the pore is very small. However, since the inclusions are treated as dimensionless (Eq. (3)) [51] and the excluded volume effect [54] is not taken into account, the local density of the inclusions at the pore edge may become unrealistically high if the inclusions favor the local shape of the membrane at the edge of the pore. Nevertheless, our purpose was only to describe the basic principles of the possible physical mechanism that determines the increased stability of pores in membrane bilayers when $C_{12}E_8$ molecules are incorporated in the membrane and to explain our experimental results (Fig. 2). Therefore, for simplicity the excluded volume effect was neglected.

Although our theoretical model may offer a possible qualitative explanation of the influence of the $C_{12}E_8$ molecules on the stability of hydrophilic pores in membrane bilayer, the uncertainties or lack in experimentally measured model parameters prevent us from precise numerical calculations of

the stable size of the hydrophilic pore. In addition, we have neglected some other important contributions to the free energy of the pore [42,43] such as non-local bending energy also called area-difference-elasticity energy [55,56], surface pressure [9,57] and electrostatic energy of the pore [46].

In conclusion, we have shown that the detergent C₁₂E₈ affects irreversible electroporation of the cell line DC3F in a similar way as it was previously demonstrated in electroporation of planar lipid bilayer as a membrane model [37]. Our theoretical considerations indicate that C₁₂E₈-lipid and C₁₂E₈-protein induced anisotropic membrane inclusions [33,36] may stabilize a hydrophilic pore that is formed during the pulse application in the membrane. Recently the existence of hydrophilic pores in the lipid membranes that can become stable under electrocompressive stress was proposed [58]. Our results could therefore be considered as a circumstantial evidence for the existence of hydrophilic pores that become stabilized by anisotropic membrane inclusions that prevent membrane re-sealing and consecutively transform the reversible electroporation into the irreversible electroporation.

Acknowledgements

This research was supported by the Ministry of Education, Science and Sport of the Republic of Slovenia through various grants. Authors wish to express their thanks to Zorka Stolič from J. Stefan Institute, Ljubljana, Slovenia, for technical assistance and Leslie Tung and Kate Stebe from Johns Hopkins University, Baltimore, USA, for stimulating our experimental work.

Appendix A

In this work dimensionless quantities are introduced. The effective thickness of a lipid monolayer r is chosen for the unit of length (Fig. 4). The variables and parameters are redefined as follows: $x/r \rightarrow x$, $r/r \rightarrow 1$, $R/r \rightarrow R$, $l/r \rightarrow l$, $C_1 r \rightarrow C_1$, $C_2 r \rightarrow C_2$, $C_{1m} r \rightarrow C_{1m}$, $C_{2m} r \rightarrow C_{2m}$, $\bar{C} r \rightarrow \bar{C}$, $\hat{C} r \rightarrow \hat{C}$, $\bar{C}_m r \rightarrow \bar{C}_m$, $\hat{C}_m r \rightarrow \hat{C}_m$. The membrane free energy

F is normalized relative to the energy $8\pi k_c$, $f = F/8\pi k_c = w_b + f_i$, where $w_b = W_b/8\pi k_c$ and $f_i = F_i/8\pi k_c$.

In the described geometrical model of the membrane bilayer segment with a circular pore in the center (Fig. 4), both membrane layers are flat in the region $R < x < l$ and bend towards each other in the region $R - r < x < R$, forming an inner half of the torus with the larger radius R and the smaller radius r . The principal membrane curvatures of the membrane can be derived from the expressions for principal curvatures of a surface obtained by the function $y(x)$ rotated around the y -axis, $C_1 = -y''(1+y'^2)^{-3/2}$ and $C_2 = -y'x^{-1}(1+y'^2)^{-1/2}$. The principal curvatures C_1 and C_2 are zero in the region $R < x < l$, where the membrane is flat (Fig. 4). In the region of the pore edge ($R - r < x < R$), the function $y(x)$ obeys the equation $(x - R)^2 + y^2 = r^2$, therefore $C_1 = 1/r$ and $C_2 = (x - R)/rx$. Knowing C_1 and C_2 , integration in the expression for the pore edge energy (Eq. (2)) can be performed. The relative pore edge energy can be then written as

$$w_b = \frac{\arcsin(1/R) + \pi/2}{(2/R)^2 \sqrt{1 + R^2}} - \frac{1}{2} \quad (\text{A1})$$

Expansion of w_b into the power series [59] of R yields $w_b = \frac{\pi}{8}(R - 0.5 \times R^{-1} + O(R^{-2}))$. For an open pore ($R > 1$) the pore edge energy $w_b(R)$ is a monotonically increasing function of R . In our range of interest, $w_b(R)$ only slightly deviates from the linear function.

To obtain the expression for the free energy of the inclusions, the parameters $\varepsilon = NkT/8\pi k_c$ and $\kappa = \xi/kTr^2$ are introduced and integration in Eq. (3) is performed. For the relative free energy of the inclusions we can write the expression:

$$f_i = -\varepsilon \ln \left[(2 + a - \pi R) \times \exp \left[-\frac{\kappa}{2} (\bar{C}_m^2 - \hat{C}_m^2) \right] + 2\tilde{I} \right] \quad (\text{A2})$$

where $a = A/4\pi r^2$ is the relative area of a flat membrane segment without a pore and \tilde{I} is:

$$\tilde{I} = \int_{R-1}^R \tilde{q} I_0(\kappa \hat{C} \hat{C}_m) \frac{x}{\sqrt{1 - (R-x)^2}} dx \quad (\text{A3})$$

with \tilde{q} defined as

$$\tilde{q} = \exp \left[-\frac{\kappa}{2} ((\bar{C} - \bar{C}_m)^2 + \hat{C}^2 + \hat{C}_m^2) \right]. \quad (\text{A4})$$

References

- [1] D.C. Chang, B.M. Chassy, J.A. Saunders, A.E. Sower (Eds.), *Guide to Electroporation and Electrofusion*, Academic Press, New York, 1992.
- [2] E. Neumann, A.E. Sowers, C.A. Jordan (Eds.), *Electroporation and Electrofusion in Cell Biology*, Plenum Press, New York and London, 1989.
- [3] M.F. Bureau, J. Gehl, V. Deleuze, L.M. Mir, D. Scherman, *Biochim. Biophys. Acta* 1474 (2000) 353.
- [4] G. Serša, B. Štabuc, M. Čemazar, B. Jančar, D. Miklavčič, *Z. Rudolf, Eur. J. Canc.* 34 (1998) 1213.
- [5] R. Heller, R. Gilbert, M.J. Jaroszeski, *Adv. Drug Deliver. Rev.* 35 (1999) 119.
- [6] L.M. Mir, *Bioelectrochemistry* 53 (2000) 1.
- [7] J.C. Weaver, Y.A. Chizmadzev, *Bioelectrochem. Bioenerg.* 41 (1996) 135.
- [8] I.G. Abidor, V.B. Arakelyan, L.V. Chernomordik, Y.A. Chizmadzev, V.F. Pastushenko, M.R. Tarasevich, *Bioelectrochem. Bioenerg.* 6 (1979) 37.
- [9] E. Neumann, S. Kakorin, K. Toensing, *Bioelectrochem. Bioenerg.* 48 (1999) 3.
- [10] A.J.H. Sale, W.A. Hamilton, *Biochim. Biophys. Acta* 148 (1967) 781.
- [11] A.J.H. Sale, W.A. Hamilton, *Biochim. Biophys. Acta* 163 (1968) 37.
- [12] W.A. Hamilton, A.J.H. Sale, *Biochim. Biophys. Acta* 148 (1967) 789.
- [13] M.P. Rols, F. Dahhau, K.P. Mishra, J. Teissie, *Biochemistry* 29 (1990) 2960.
- [14] M.P. Rols, J. Teissie, *Biophys. J.* 75 (1998) 1415.
- [15] M.C. Vernhes, P.A. Cabanes, J. Teissie, *Bioelectrochem. Bioenerg.* 48 (1999) 17.
- [16] M.P. Rols, J. Teissie, in: M. Blank (Ed.), *Electricity and Magnetism in Biology and Medicine*, San Francisco Press, San Francisco, 1993, p. 151.
- [17] H. Wolf, M.P. Rols, E. Boldt, E. Neumann, J. Teissie, *Biophys. J.* 66 (1994) 524.
- [18] S.W. Hui, in: J.A. Nickoloff (Ed.), *Methods of Molecular Biology Vol 48: Animal Cell Electroporation and Electrofusion Protocols*, Humana Press, Towota, 1995, p. 29.
- [19] T. Kotnik, F. Bobanovič, D. Miklavčič, *Bioelectrochem. Bioenerg.* 43 (1997) 285.
- [20] T. Kotnik, D. Miklavčič, T. Slivnik, *Bioelectrochem. Bioenerg.* 45 (1998) 3.
- [21] J. Teissie, M.P. Rols, *Biophys. J.* 74 (1998) 1889.
- [22] J. Teissie, P. Conte, *Bioelectrochem. Bioenerg.* 19 (1988) 49.
- [23] A. Maček-Lebar, N.A. Kopitar, A. Ihan, G. Serša, D. Miklavčič, *Electro. Magneto. Biol.* 17 (1998) 255.
- [24] M. Muraji, H. Taniguchi, W. Tatebe, H. Berg, *Bioelectrochem. Bioenerg.* 48 (1999) 485.
- [25] S. Schreier, S.V.P. Malheiros, E. de Paula, *Biochim. Biophys. Acta* 1508 (2000) 210.
- [26] B. Deuticke, *Biochim. Biophys. Acta* 163 (1968) 494.
- [27] M. Le Maire, S. Kwee, J.P. Andesen, J.V. Møller, *Eur. J. Biochem.* 129 (1983) 525.
- [28] M. LeMaire, J.V. Møller, P. Champeil, *Biochemistry* 26 (1987) 4803.
- [29] U. Kragh-Hansen, M. le Maire, J.V. Møller, *Biophys. J.* 75 (1998) 2932.
- [30] H. Hägerstrand, J. Bobacka, M. Bobrowska-Hägerstrand, V. Kralj-Iglič, M. Fošnaric, A. Iglič, *Cell Mol. Biol. Lett.* 6 (2001) 161.
- [31] R.L. Thurmond, M.F. Otten, Brown, K. Beyer, *J. Phys. Chem.* 98 (1994) 972.
- [32] H.H. Heerklotz, H. Binder, H. Schmiedel, *J. Phys. Chem.* 102 (1998) 5363.
- [33] M. Bobrowska-Hägerstrand, V. Kralj-Iglič, A. Iglič, K. Bialkowska, B. Isomaa, H. Hägerstrand, *Biophys. J.* 77 (1999) 3356.
- [34] J.V. Møller, M. le Maire, *J. Biol. Chem.* 268 (1993) 18659.
- [35] J.B. Fournier, *Phys. Rev. Lett.* 76 (1996) 4436.
- [36] A. Iglič, V. Kralj-Iglič, B. Božič, M. Bobrowska-Hägerstrand, B. Isomaa, H. Hägerstrand, *Bioelectrochemistry* 52 (2000) 203.
- [37] G. Troiano, K. Stebe, V. Sharma, L. Tung, *Biophys. J.* 75 (1998) 880.
- [38] M. Šentjerc, M. Zorec, M. Čemazar, M. Auersperg, G. Serša, *Cancer Letts.* 130 (1998) 183.
- [39] D. Marsh, in: E. Grell (Ed.), *Membrane Spectroscopy*, Springer, Berlin, 1981, p. 51.
- [40] T. Kotnik, A. Maček-Lebar, D. Miklavčič, L.M. Mir, *BioTechniques* 28 (2000) 921.
- [41] M. Puc, K. Flisar, S. Reberšek, D. Miklavčič, *Radiol. Oncol.* 35 (2001) 203.
- [42] J.C. Neu, W. Krassowska, *Phys. Rev. E.* 59 (1999) 3471.
- [43] S. May, *Eur. Phys. J.E.* 3 (2000) 37.
- [44] V. Kralj-Iglič, A. Iglič, H. Hägerstrand, P. Peterlin, *Phys. Rev. E.* 61 (2000) 4230.
- [45] J. Israelachvili, *Intermolecular and Surface Forces*, Academic Press, 1992, p. 1992.
- [46] M.D. Betterton, M.P. Brenner, *Phys. Rev. Lett.* 82 (1999) 1598.
- [47] W. Helfrich, *Naturforsch* 28C (1973) 693.
- [48] L.D. Landau, E.M. Lifshitz (Eds.), *Theory of Elasticity*, Butterworth-Heinemann, Oxford, Boston, 1997.
- [49] B. Farango, in: R. Lipowsky, D. Richter, K. Kremer (Eds.), *The structure and conformation of Amphiphilic Membranes*, Springer, Berlin, New York, 1992.

- [50] V. Kralj-Iglič, S. Svetina, B. Zekš, *Eur. Biophys. J.* 24 (1996) 311.
- [51] V. Kralj-Iglič, V. Heinrich, S. Svetina, B. Zekš, *Eur. Phys. J. B.* 10 (1999) 5.
- [52] P.A. Barneveld, J.M.H.M. Scheutjens, J. Lyklema, *Langmuir* 8 (1992) 3122.
- [53] K.M. Melikov, V.A. Frolov, A. Shcherbakov, A.V. Samsou, Y.A. Chizmadzev, *Biophys. J.* 80 (2001) 1829.
- [54] V. Kralj-Iglič, A. Iglič, *J. Phys. II. France* 6 (1996) 477.
- [55] E.A. Evans, *Biophys. J.* 30 (1980) 265.
- [56] R. Mukhopadhyay, G. Lim, M. Wortis, *Biophys. J.* 82 (2002) 1756.
- [57] Y.A. Chizmadzev, F.S. Cohen, A. Shcherbakov, J. Zimmerberg, *Biophys. J.* 69 (1995) 2489.
- [58] S.J. Marrink, E. Lindahl, O. Edholm, A.E. Mark, *J. Am. Chem. Soc.* 123 (2001) 8638.
- [59] G. Tomšič, T. Slivnik. *Higher Mathematics*, FE, Ljubljana, 1996.